



- Faridabad • Sonipat • Kolkata • Mumbai • Pune • Ahmedabad
- Chennai • Bangalore • Hyderabad

Tensile Testing Machine Computerised – Zeus Ultimo



Model No. TTM-D (C) Zeus Ultimo

Tensile Testing Machine Computerised is a consistent tool that helps the manufacturer in testing the breaking, tensile and compression strength of various materials, components and finished products. It is based on the principle of Constant rate of extension (CRE). PRESTO Tensile Testing Machine Computerised is manufactured under various test standards such as ASTM D412, ASTM D429-73, ASTM D624, ATM D638-01, ASTM D76, IS 13360-5-7, IS 3400(Part1-1987).

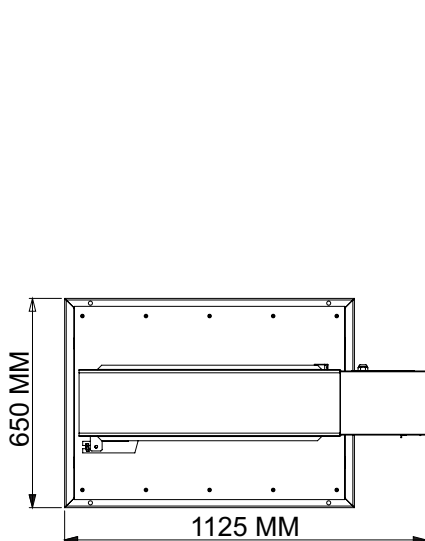

Top View

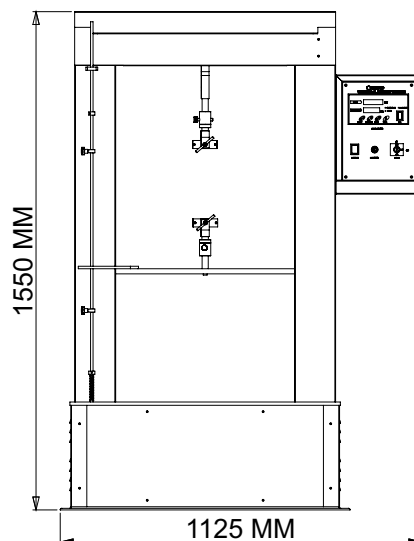

Front View

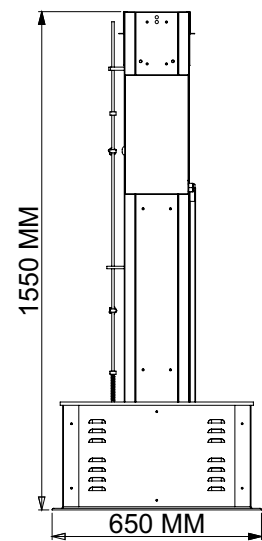

Side View

* for 500 Kgf capacity model





Presto Stantest Pvt. Ltd.

I-42, DLF Industrial Area Phase-1, Delhi Mathura Road, Faridabad 121003, Haryana, India
P : 9210 903 903, +91 129 4272727, 93111 24302 E : info@prestogroup.com

• Faridabad • Sonipat • Kolkata • Mumbai • Pune • Ahmedabad
• Chennai • Bangalore • Hyderabad

www.prestogroup.com



Features :

- Advanced load sensor sensing through advanced electronics.
- Speed Control through Variable Frequency drive automation by Graphic user interface PC.
- Highly sensitive load sensor with linearity feature and repeatability
- Cross head travel length: 800 mm without grips
- Twin column rugged structure
- Safety limit switches for over travel safety
- Hardened lead screws/ball screws for frictionless movement
- Load cell calibrated by NABL approved proving ring/dynamometers
- Advanced Navigation System
- High accurate micro-controller based system controls with integrated software
- User Friendly software with intuitive icons and robust architecture
- Inbuilt hardware/software CD
- Easy Data Management. User programmable product identification, lot no., shape of specimen, company name, operator details etc.
- USB compatible for high speed data transfer
- Export Test report in excel format
- Print preview of test reports with Zoom Feature available
- Online test run status can be viewed graphically or in raw data form
- Secured working with key protection feature
- Ease of use features: Graph setup, test control wizard, formulae/result calculations, reports, live test panel.
- Graph setup: user defined graph scale/range with Graph Title
- Test Control Wizard to set test parameters like tension, compression, changeable units in Kgs/N/lbs or cm/mm/inch.
- Automatic end test/return to home position through software interface after completion of test.
- Immediate analysis of results after test with complete accuracy & precision.
- Option to email test reports
- Single Test start with one click entry of the mouse.

Reliable and user friendly software in various industries like rubber, plastics, automotive, polymers, textiles, R&D labs, production, material testing. A comprehensive Universal testing solution, PRESTO tensile testing machine computerized – Zeus Ultimo is a one stop solution for studying tensile properties of various products.

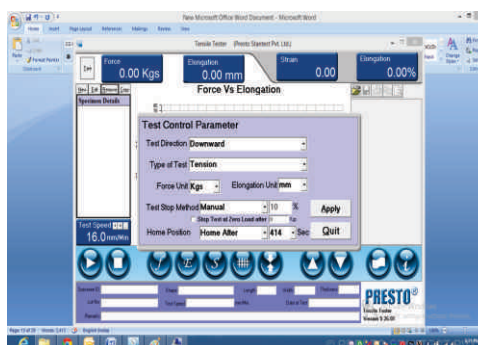
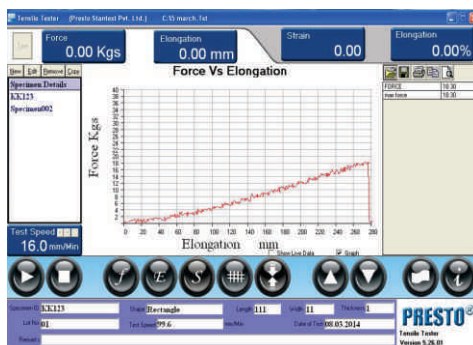



Additional Fixtures:

S. No.	Tests & Their Fixture Specifications	Indicative Images
1.	<p>Cap Snap ON test</p> <p>Specifications:</p> <p>Set of dished Plates, designed for a limited range of dia of container and closure.</p>	
2.	<p>Cap Pull test</p> <p>Specifications:</p> <p>1X Machined-Hooked, Split-cylindrical fixture with limited adjustable gap to pull a limited range of closure geometries. 1X double screw fixture for bottle.</p> <p>NOTE: Qty of fixtures may vary depending on range of samples to be tested.</p>	
3.	<p>Flip Pull test</p> <p>Specifications:</p> <p>1X Machined-Hooked-Hinged fixture for Pulling Flip-caps (one design per cap dia). 1X Split-round grip for limited dia of bottle-base.</p> <p>NOTE: Different lower fixtures may be needed for bottles and tubes.</p>	
4.	<p>Top Load test (Bottle Compression)</p> <p>Specification:</p> <p>Set of dished Plates, designed for limited range of dia of container and closure.</p>	
5.	<p>Peel Strength Test (Delamination Test)</p> <p>Specification :</p> <p>Set of Vice type grips with rubber padding, width 50 mm.</p> <p>NOTE: Standard test is 180 degree.</p>	
6.	<p>Seal Strength Test</p> <p>Specification :</p> <p>Set of Vice type grips 100 mm wide.</p>	
7.	<p>Elongation at Break</p> <p>Specification :</p> <p>Not displayed or reported, but can be derived from graph (computerised machine only).</p>	

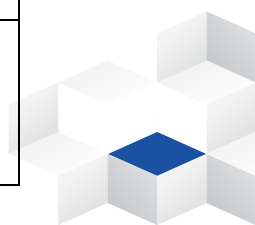



Presto Stantest Pvt. Ltd.

I-42, DLF Industrial Area Phase-1, Delhi Mathura Road, Faridabad 121003, Haryana, India
 P : 9210 903 903, +91 129 4272727, 93111 24302 E : info@prestogroup.com



- Faridabad
- Sonipat
- Kolkata
- Mumbai
- Pune
- Ahmedabad
- Chennai
- Bangalore
- Hyderabad

www.prestogroup.com

Key Specification

Display	Graphical with test data output through Inbuilt Software
Power	220V , Single / Three phase, 50 Hz
Accuracy	± 2% at Full Load (with master load)
Standard Speed	50-500 mm/min *Optional through computer software
Grip to Grip Separation	Min 25mm and Max. 700mm (applicable only with vice type standard grip)
Digital load indicator	7 segment LED Display (optional as per request)

Capacities Available

Capacities (Kg.)	Least Count
5	1gm
10	1gm
20	2gm
50	5gm
100	10gm
250	100gm
500	200gm
1000	500gm
2500	1kg
5000	2kg
10000	5kg

Highlights:

Drive Mechanism	Variable Frequency AC Drive
Safety	Yes
Grippers (optional added based on requirement)	<ul style="list-style-type: none"> • Vice Type (Standard Gripper) • Flexural • Compression Plate • Wedge Type • Roller Type
Communication Converter	USB / RS 485
Material	Mild Steel
Finish	Powder coated Havel Gray & Blue combination finish and bright chrome / zinc plating for corrosion resistant finish
Dimensions	1125 x 650 x 1550 mm

* Other capacity available as per requirement.

* Computer, Printer, UPS & Table not part of supply

Optional Features:

Grippers for different test material also available.

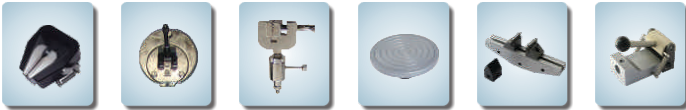

Self Tighting grip Wedge Type grip Vice Type grip Compression Plate Flexural Roller Type Grip

Thank you customers for choosing us as your partners in growth !



*All the above logos are the sole property of their respective owners and are used purely for depiction purposes only.

OUR OTHER PRODUCTS :-

Box Compression Tester	Scuff Resistance Tester	Tensile Tester Digital	Spectrocolorimeter	Cobb Sizing Tester	Digital GSM Balance

